

PALLETIZING

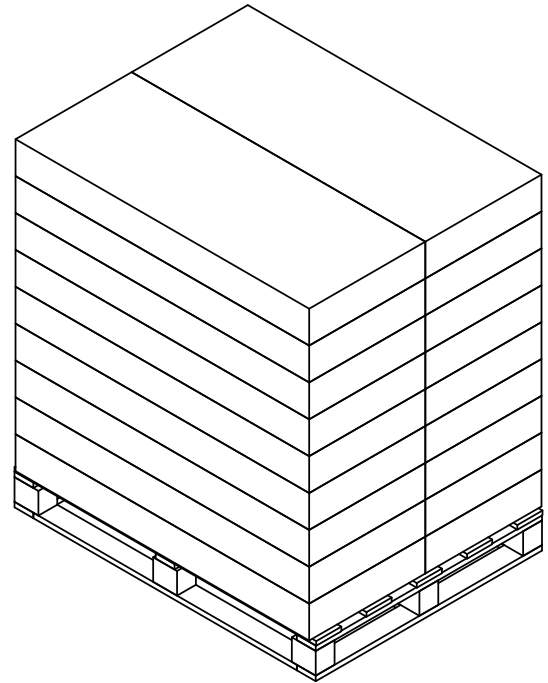

Rev.	Latest Revision / Description						
A	Første udgave.						
Item number	Component	Pcs.	L	W	T	Gross weight in kg	Net weight in kg
089056	Palle, TS14, Special.	1	1200	900	139		
Box 1 of 3		18	1168	462	127	25,3	24,4
tvilum	Vitrine 1 låge + 1 glaslåge + 1 skuffe Ry		INIT:	JR	DATE :	25-04-2019	
			REVISION:	A	Approved by:	JR	
86008			DWG.NO.		86008-70		

PALLETIZING

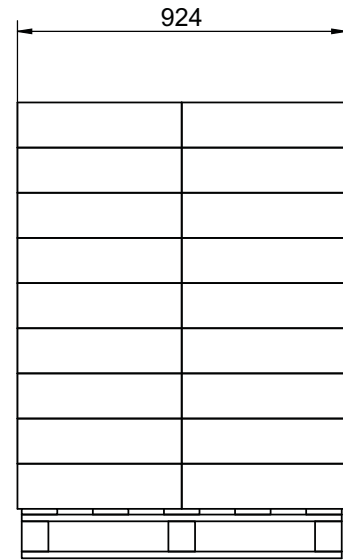
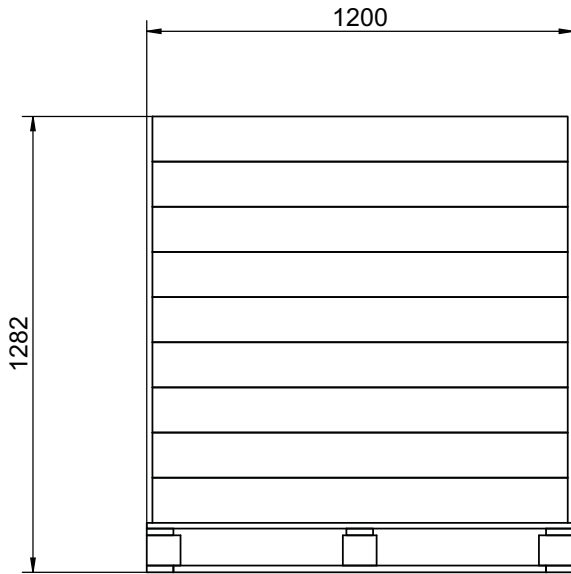
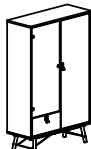
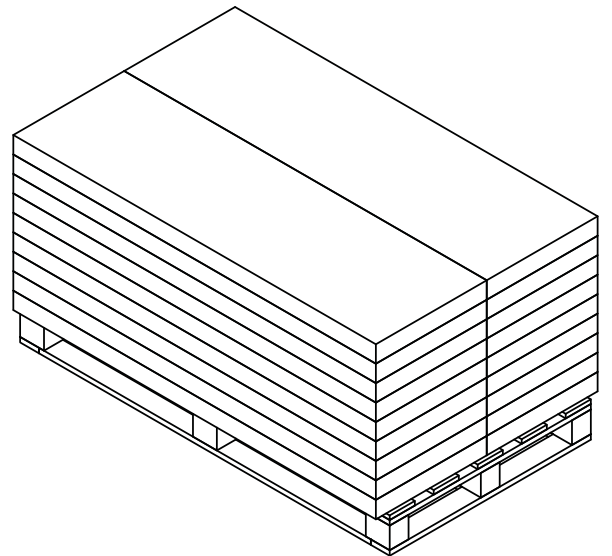
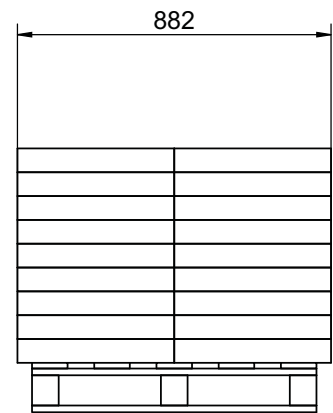
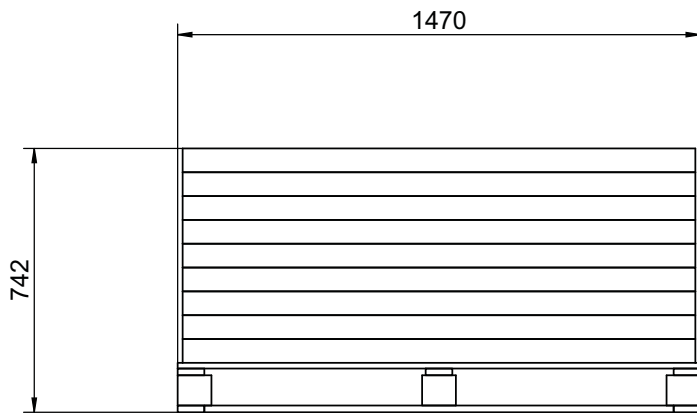

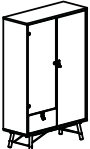
Rev.	Latest Revision / Description						
A	Første udgave.						
Item number	Component	Pcs.	L	W	T	Gross weight in kg	Net weight in kg
089309	Palle, TS56, Special.	1	1470	800	139		
Box 2 of 3		18	1442	441	67	20,2	19,5
tvilum	Vitrine 1 låge + 1 glaslåge + 1 skuffe Ry		INIT:	JR	DATE :	25-04-2019	
			REVISION:	A	Approved by:	JR	
86008			DWG.NO.		86008-70		

PALLETIZING

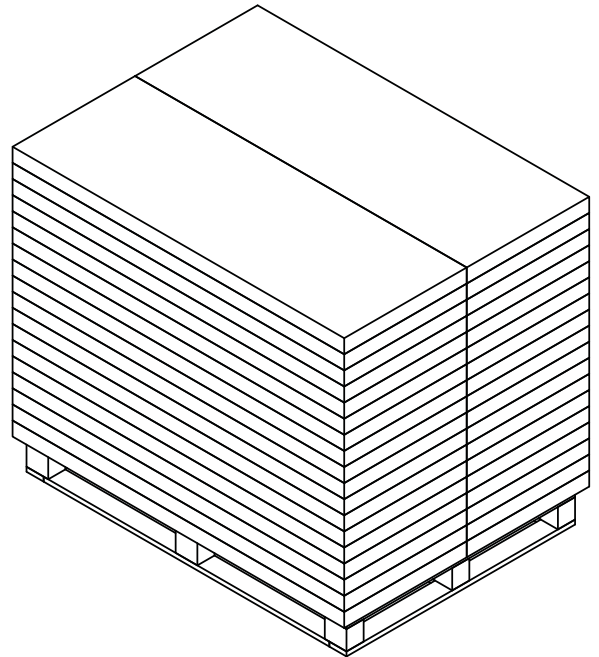
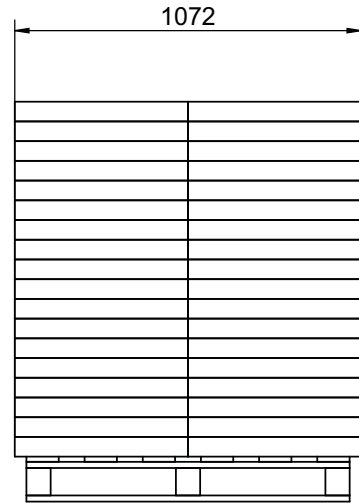
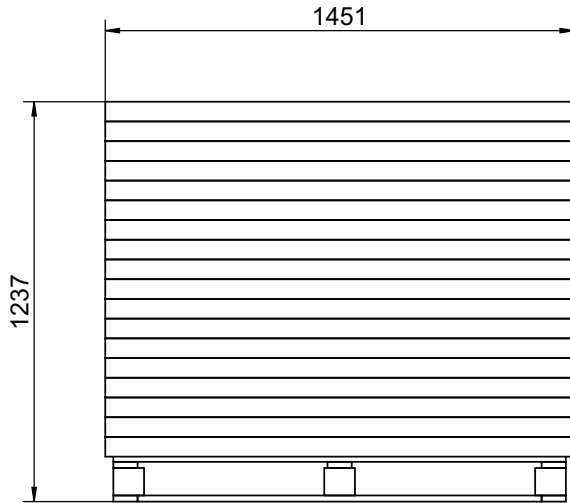

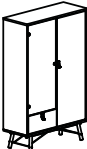
Rev.	Latest Revision / Description						
A	Første udgave.						
Item number	Component	Pcs.	L	W	T	Gross weight in kg	Net weight in kg
089143	Palle, TS29A, Special.	1	1400	1000	139		
Box 3 of 3		36	1451	536	61	23,5	22,7
tvilum 86008	Vitrine 1 låge + 1 glaslåge + 1 skuffe Ry		INIT:	JR	DATE :	25-04-2019	
			REVISION:	A	Approved by:	JR	
		DWG.NO.	86008-70				