

PALLETIZING

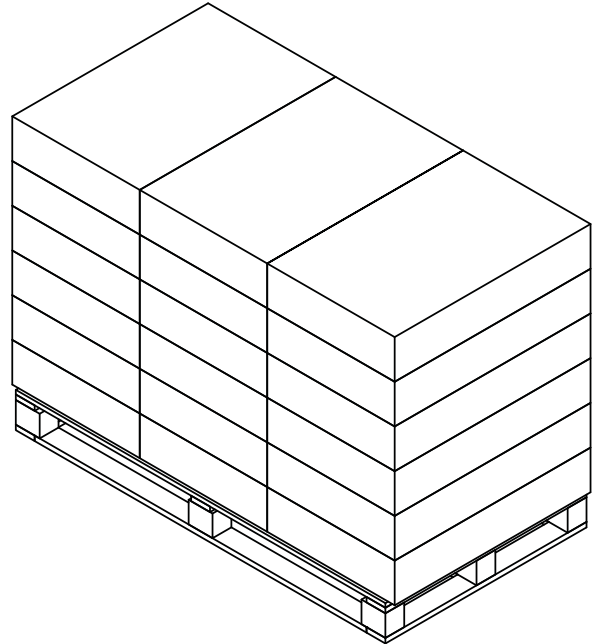

Rev.	Latest Revision / Description								
A	Første udgave.								
Item number	Component	Pcs.	L	W	T	Gross weight in kg	Net weight in kg		
089309	Palle, TS56, Special.	1	1470	800	139	16 kg.			
Box 1 of 2		18	779	507	154	22,1	21,2		
tvilum 79670	Skænk 2 låger + 3 skuffer Madrid					INIT:	JR	DATE :	19-03-2020
						REVISION:	A	Approved by:	JR
		DWG.NO.			79670-70				

PALLETIZING

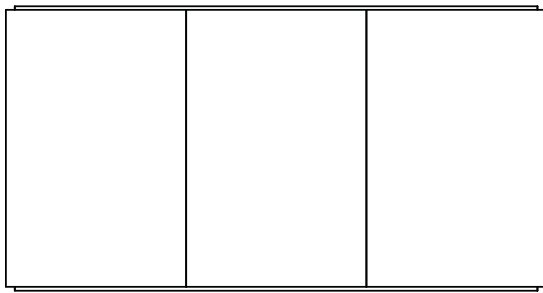
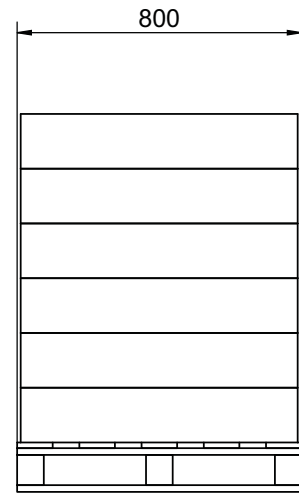
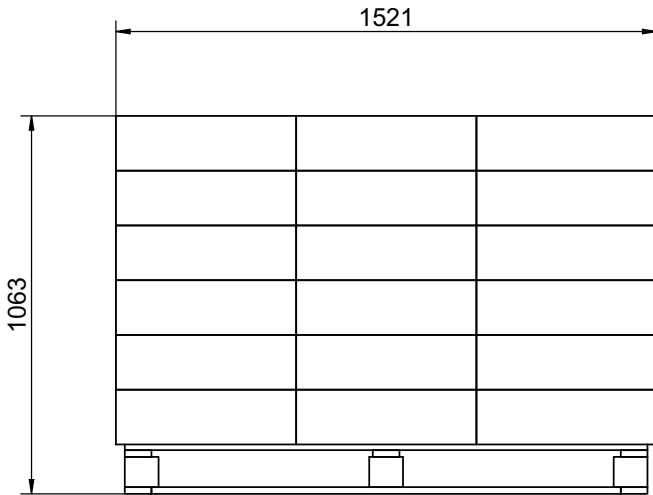
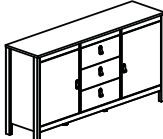
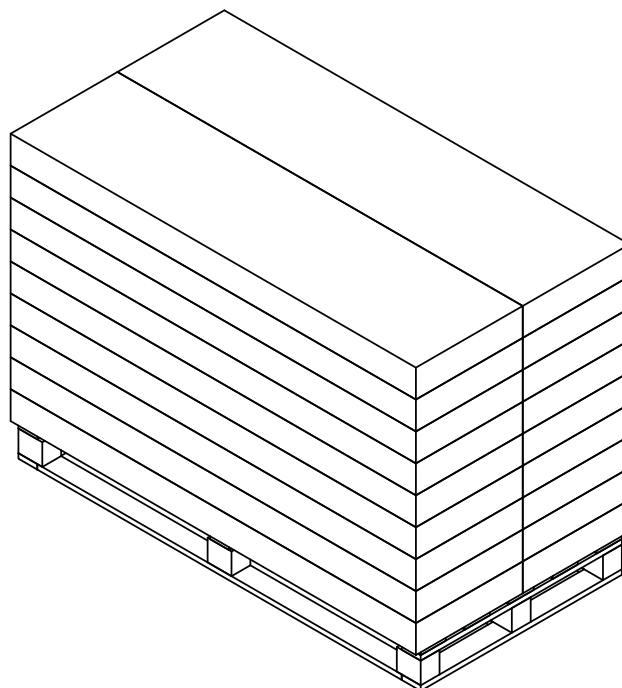
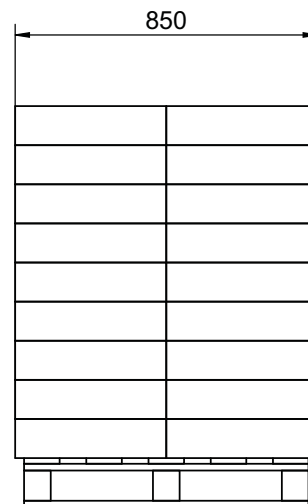
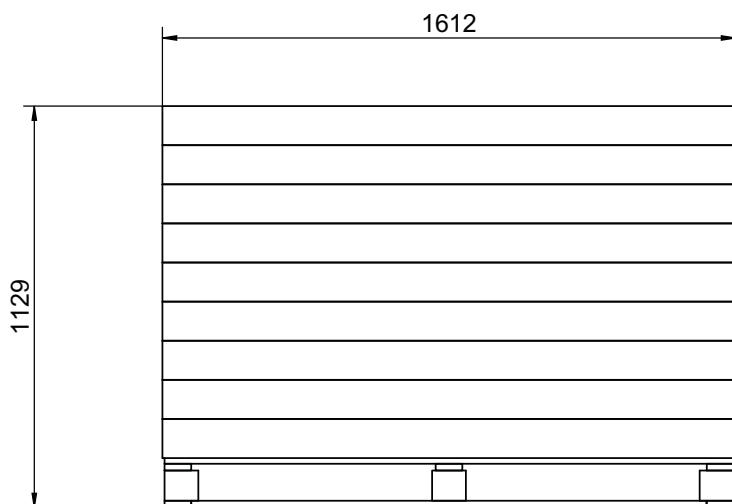

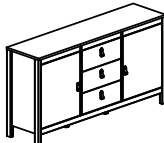
Rev.	Latest Revision / Description						
A	Første udgave.						
Item number	Component	Pcs.	L	W	T	Gross weight in kg	Net weight in kg
089588	Palle, TS61, Special.	1	1600	800	139	17 kg.	
Box 2 of 2		18	1612	425	110	26,7	25,5
tvilum 79670	Skænk 2 låger + 3 skuffer Madrid		INIT:	JR	DATE :	19-03-2020	
			REVISION:	A	Approved by:	JR	
			DWG.NO.	79670-70			